



- 可选量程范围：10kg 到 2t
- 输出信号：毫伏
- 受力方式：双向拉压或称重

- Measuring Range
10kg upto 2t
- Output: mV
- Compression/Tension/Weighing

技术指标 Technical Specification

可选量程 Measuring range	10、20、30、50、100、200 500、1000、2000	(kg)
安全过载 Service load	150	(% F. S.)
极限过载 Limit load	200	(% F. S.)
零点输出 Zero signal tolerance	<±1	(% F. S.)
线性 Linearity	<±0.5	(% F. S.)
重复性 Repeatability	<±0.5	(% F. S.)
蠕变(30分钟) Creep error (30 min)	<±0.5	(% F. S.)
滞后 Hysteresis	<±0.5	(% F. S.)
响应时间 Response time	<1	(ms)
灵敏度温度系数 Temp. coefficient of sensitivity	<0.015	(% F. S. / °C)
零点温度系数 Temp. coefficient of zero blance	<0.1	(% F. S. / °C)
抗偏载能力 Limit lateral load	10	(% F. S.)
额定负载形变 Rated displacement	0.5	(mm)

电气特性 Electrical Specification

推荐激励电压 Excitation voltage recommended	5 ~ 12	(V)
最大激励电压 Max. excitation voltage	15	(V)
输入阻抗 Input resistance	410 ± 15	(Ω)
输出阻抗 Output resistance	350 ± 5	(Ω)
绝缘电阻(直流500V) Insulation resistance (@500VDC)	>5000	(MΩ)

环境条件 Environments

工作温度 Operation temperature	-30 ~ 65	(°C)
储存温度 Storage temperature	-40 ~ 85	(°C)
相对湿度 Rel. humidity	95	(% r. H.)

接线示意图 Wiring Guide

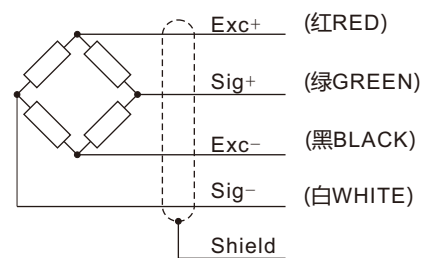

外形尺寸 Dimension (mm)

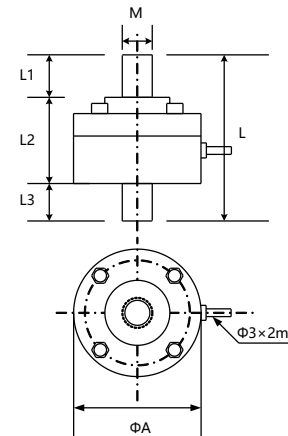

额定载荷 (kg)	传感器对应尺寸 (单位: mm±1mm)					
	ΦA	L	L1	L2	L3	M
10-30	26	37.5	11.5	14	12	M5
50-1000	51	70	17	34	19	M12
2000	51	75	17	39	19	M12

安装受力方式 Working Diagram

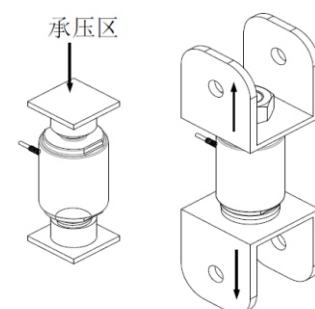

以上参数仅供参考 如有更改 恕不另行通知
The above parameters is only for reference are subject to change without notice